



Providing Quality Products
To The World Since 1988

INOFOAM SOAP & SANITIZER DISPENSERS



EXLI000FOAM-BB-P



LI000FOAM-CB-P



EXLI000FOAM-P



LI000FOAM-WB-P



LI000FOAM-TRANS



LI000FOAM-SM-P

- Contemporary color and finish combinations
- Multiple output options:
 - Foam output from: 0.7 mL to 1.0 mL
- Locking option available
- Large product viewing window
- Space-saving and durable design
- One-handed manual push operation
- ADA compliant



Providing Quality Products
To The World Since 1988

INOFOAM SOAP & SANITIZER DISPENSERS

SPECIFICATIONS

Capacity per Dispenser:

1000 mL (33.8 FL. OZ.)

Case Specifications:

12 Units per Case,
48 Cases per Pallet,
Case Weight - 16 lbs. (7.14 kg)

Dispenser Dimensions:

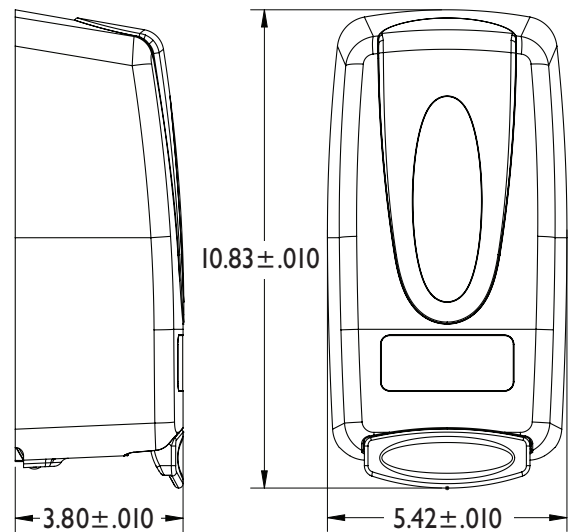

ACCESSORIES

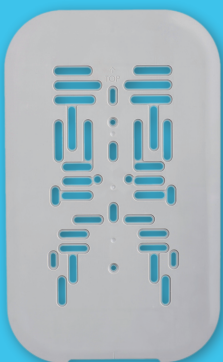

Wall Plate

Locking
Bar



Dispenser Key



Stand



Graphic Options

Hot Stamp or
Decal (MOQ)

LOGO
Your Message

Drip
Tray

