



DART[®]

OUR STORY BEGINS

Established in 1937, Dart Manufacturing Company found success making products like plastic key cases, steel tape measures, ID tags for the armed services and the iconic 1950's Marble Race Game. After 20 years of business, the father-and-son team of W.F. and W.A. Dart shifted their focus to developing a machine that would produce high-quality foam cups from a somewhat new material called expandable polystyrene. On April 20, 1960, the Darts shipped their first foam cup order, and by 1963 had changed the name of their company to Dart Container Corporation.

THEN



NOW

In the 55-plus years since, we've strategically expanded our product lines and geographic markets. Today, we have 16,000 employees at more than 40 facilities worldwide providing a broad range of foodservice packaging solutions to customers around the globe.

DART TODAY



40+
locations



16,000
people



6
countries



3,000
products

WE'RE ONE OF THE
LARGEST MANUFACTURERS
OF FOODSERVICE PACKAGING
IN THE WORLD

We make some of the most recognizable brands and products that people use every day in restaurants, hospitals, schools and homes. Our products include cups, dinnerware, cutlery, straws and deli and portion containers made from materials such as paper, foam and rigid polystyrene and polypropylene, PET and sugarcane—all designed with the features, advantages and benefits our customers want and need.



WE UNDERSTAND

that our everyday decisions
have an impact on the
environment, our communities
and our bottom line.

At Dart, designing efficient products, processes and procedures is everyone's job. This makes for a successful business as well as effective environmental stewardship. We've also built our company with an emphasis on vertical integration. By managing as many steps in the manufacturing process as practical, we've achieved a high level of efficiency and environmental responsibility in the design, production and distribution of our products.

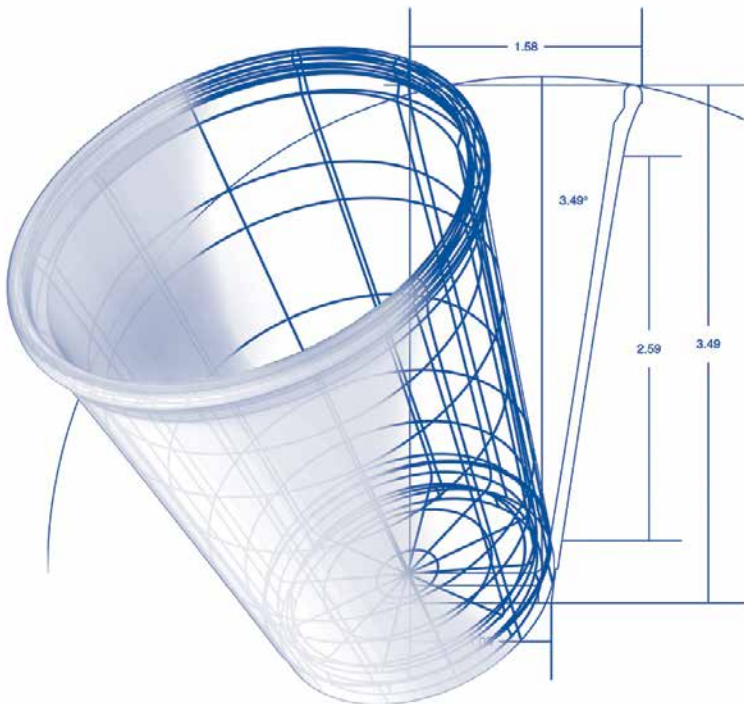

How We

REDUCE

Proactive approaches for responsible manufacturing

- We cure inks with UV light, avoiding emissions typically associated with solvent-based printing inks.
- The amount of material used to manufacture many of our products has been reduced over time without affecting product performance.
- The amount of material used to package our products, which includes both corrugated cartons and plastic films, also has been reduced over time.
- We have an active re-lamping program across our manufacturing facilities, replacing fluorescent lighting with more energy-efficient LED lights.



How We

REUSE

Low-impact production and business practices

- At many of our facilities, we recover heat from the cup-making process to warm our buildings.
- Our largest manufacturing plant uses landfill gas to power turbines that generate 45 percent of the electricity we need to manufacture our products.
- We collect clean scrap from our production processes and put it back into use to make more products.



How We

RECYCLE

Innovative material usage and industry-leading programs

- We are the award-winning industry leader in creating and promoting recycling opportunities for polystyrene foam #6. We've operated take-back programs since 1990 and created solutions for communities to collect all polystyrene foam #6—not just foam foodservice packaging. The recycled foam is used by manufacturers to make picture frames, baseboards, crown molding and other useful items.
- The Bare® by Solo® brand is the industry's first full line of foodservice products made using recycled, recyclable, compostable or renewable materials.
- We have robust recycling programs for the collection of everything from foam to paper to batteries to tires at all our facilities.



WE LOVE

our communities



*Dart employees
all over the
world are taking
part in projects
that improve the
lives of others*

Enriching our world and supporting the communities where our employees live and work is important to Dart. As a corporation, we provide financial support and products to help such organizations as the American Cancer Society and American Red Cross fulfill their meaningful missions. We also created our Dart Community Action Team (DCAT) program to facilitate and encourage volunteerism in local environmental projects, such as roadway and river clean-ups and graffiti removal efforts. Through DCAT projects and other events like blood drives and fundraisers, our employees volunteer hundreds of hours each year to support their local communities.



4.5 Million Cups

That's the number of cups Dart has donated to the American Red Cross since 2001.



115,000+ Dollars

That's how much Dart has donated to the American Cancer Society since 2013. Since 2010, we've made about 200 financial gifts in Dart communities worldwide.





For more information about Dart Container, visit:

DartContainer.com

Dart.jobs

SoloCup.com

HomeforFoam.com

FoamFacts.com